

Memtech, Inc.

9033 General Dr.
Plymouth, MI 48170

Ph: 800-634-4471
(734) 455-8550
fax: (734) 455-8552
web: flex-guard.com

ORDERING INFORMATION AND OTHER **FLEX-GUARD** SOLUTIONS
CAN BE FOUND ON-LINE -->>> www.flex-guard.com

FLEX-GUARD

Brush Seals INTERNAL COIL

Design Sheet

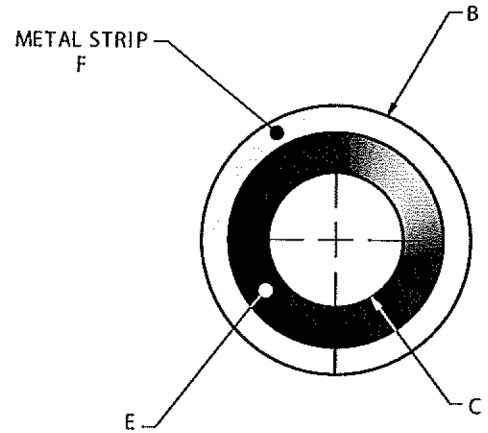
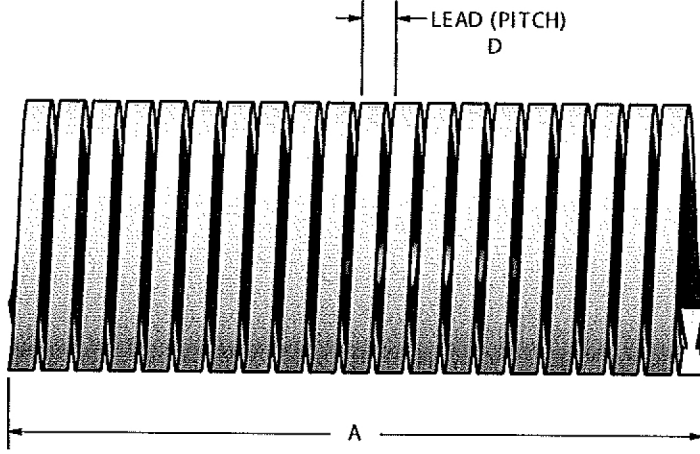

Please Complete Applicable Information:

A. Brush Face Length _____

B. Outside Diameter _____

C. Inside Diameter _____

D. Coil Style:

Closed - Lead: _____

Open - Lead: _____

E. Brush Filling:

Type _____
[nylon, polypropylene]

Bristle Diameter _____

Color _____ crimped level

F. Metal Channel Size

width x height

#4 3/16 (.187) x 3/16 (.187)

#7 5/16 (.312) x 5/16 (.312)

Other _____

G. Channel Material

Galvanized

Stainless Steel

H. Approximate RPM: _____

I. Wet or Dry Use: _____

J. Bristle Density light med heavy

K. Mounting Clips yes no

L. Quantity per Order: _____

M. Estimated Annual Usage: _____

N. Brush Application:

O. Comments/Contact Information:

- Please indicate any critical tolerances.
- We manufacture the brush to fit "snug" on the customer's shaft unless otherwise specified.
- Brushes are wound right hand unless otherwise specified.
- Brushes are supplied unmounted.

Other Available Brush Seal Shapes

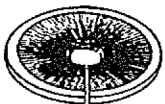

Disk & Ring

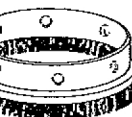

Shroud



Cup Type Ring